



**K H K SCAFFOLDING
& FORMWORK L.L.C.**



**Frame System
Light Duty**

Light Duty Frames

Light Duty Frames

- The system has built in spigot and are light weight which allows faster assembly and dismantling
- No skilled labour required
- The frame has tubular brace for better rigidity

Different Light Duty Frames Available Are:

- a) Italian frame
- b) Single ladder frame
- c) Double ladder frame
- d) Beatty frame

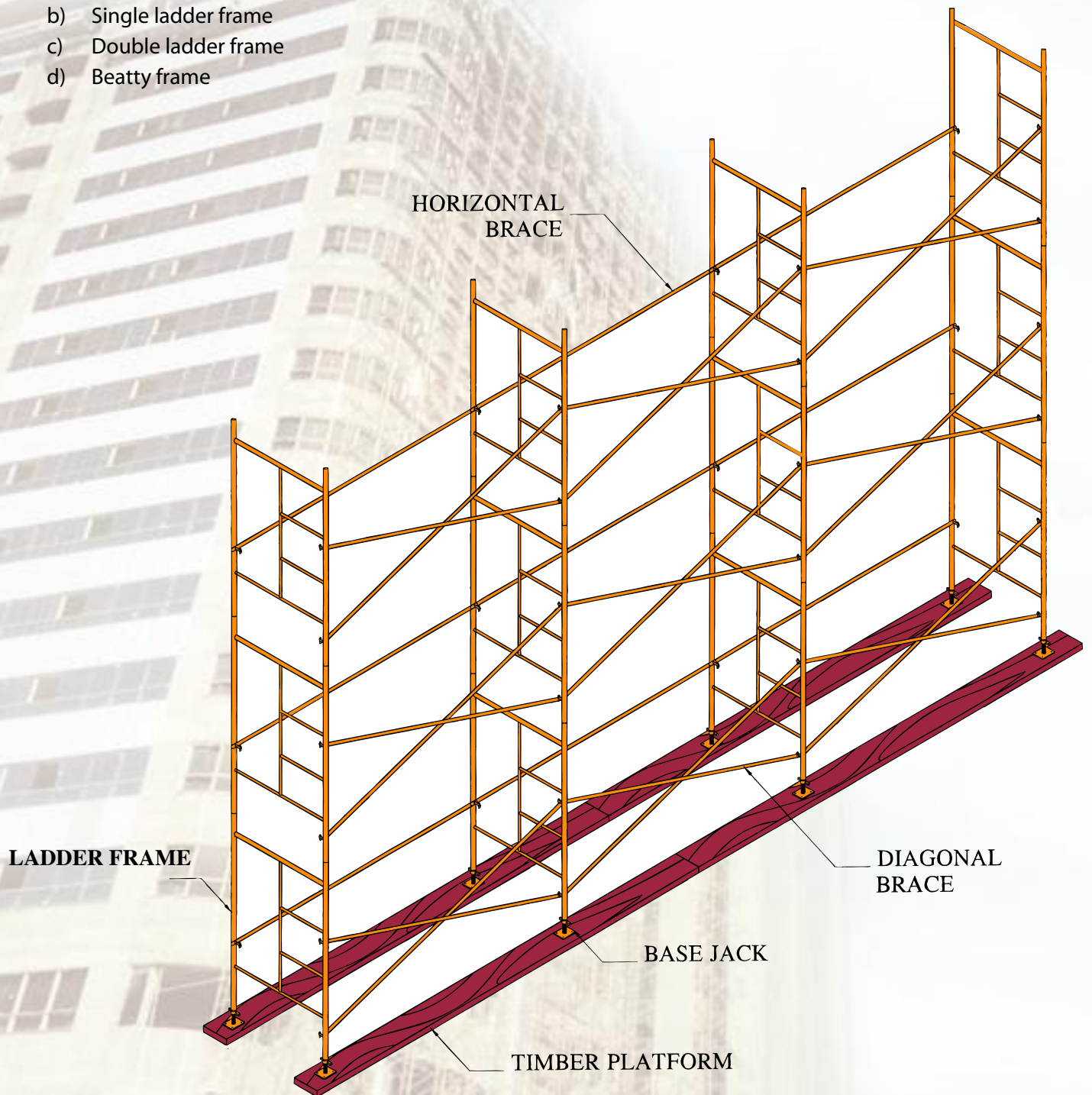

Light Duty Frames

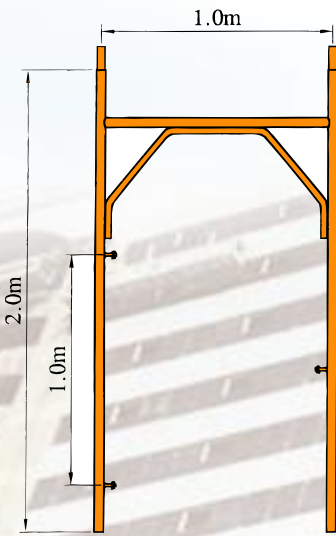

ITALIAN FRAME

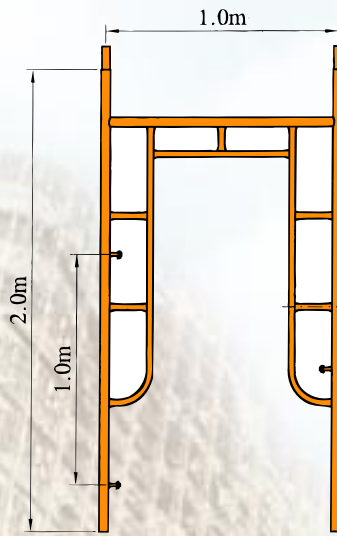

DOUBLE LADDER FRAME

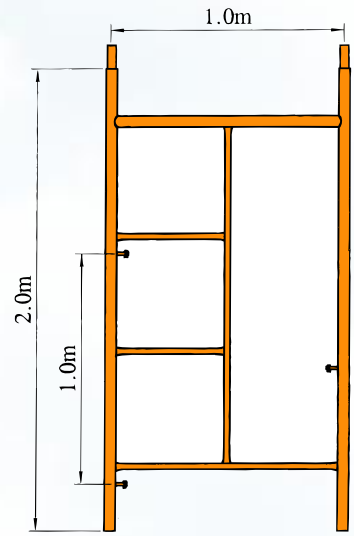

SINGLE LADDER FRAME

Vertical tubes of the frame are made of $\varnothing 48.3 \times 2$ mm tube

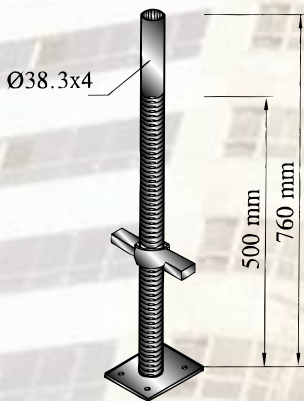

BASE JACK

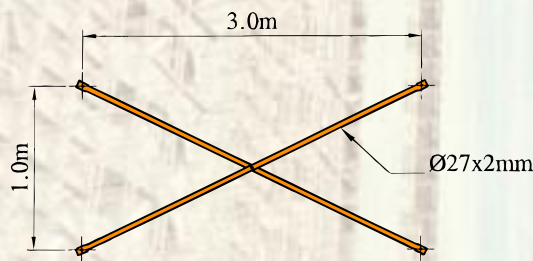

DIAGONAL BRACE

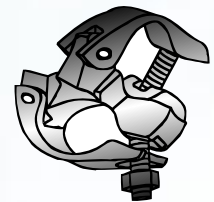

DOUBLE COUPLER

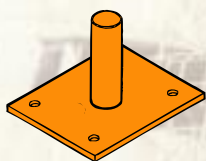

PLAIN BASE PLATE

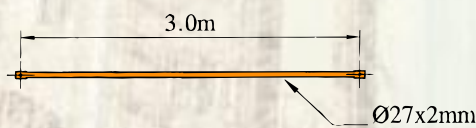

HORIZONTAL BRACE

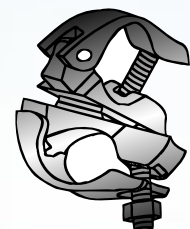

SWIVEL COUPLER

Light Duty Frames

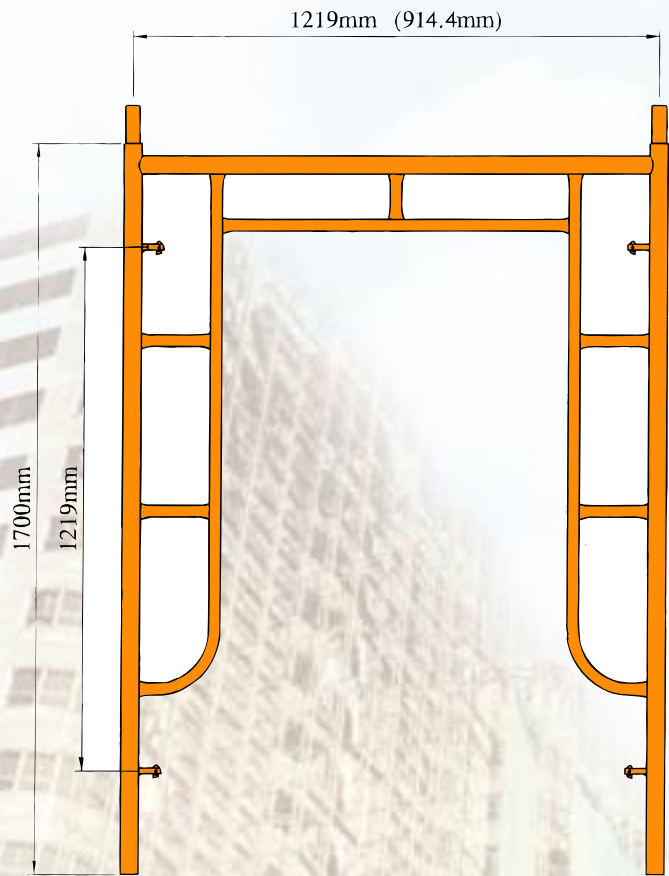

BEATTY FRAME

Vertical tubes of the frame are made of $\phi 42 \times 2$ mm tube

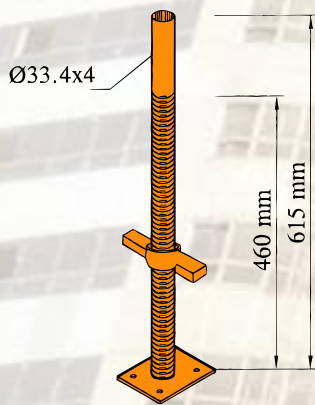

BASE JACK

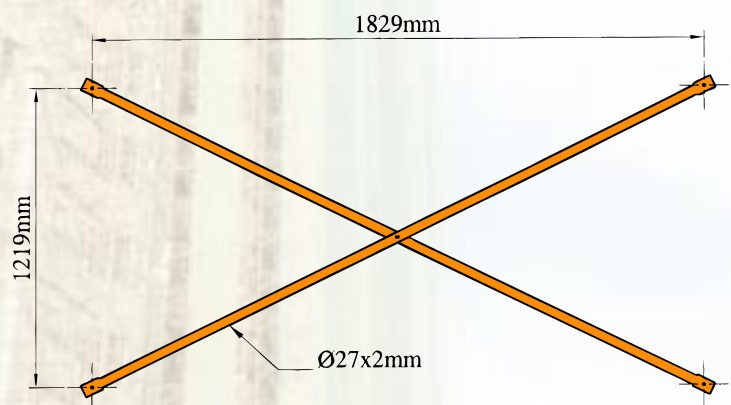

CROSS BRACE

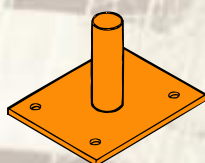

PLAIN BASE PLATE

Light Duty Frames

KHK Access Scaffolding Chart

1. AREA M ²	60.00	120.00	180.00	240.00	300.00	360.00	420.00	480.00	540.00	600.00	660.00	20.00
2. VERT. FRAME	20	30	40	50	60	70	80	90	100	110	120	
3. DIAG/HOR. BRACE	10	20	30	40	50	60	70	80	90	100	110	
	54.00	108.00	162.00	216.00	270.00	324.00	378.00	432.00	486.00	540.00	594.00	18.00
	18	27	36	45	54	63	72	81	90	99	108	
	9	18	27	36	45	54	63	72	81	90	99	
	48.00	96.00	144.00	192.00	240.00	288.00	336.00	384.00	432.00	480.00	528.00	16.00
	16	24	32	40	48	56	64	72	80	88	96	
	8	16	24	32	40	48	56	64	72	80	88	
	42.00	84.00	126.00	168.00	210.00	252.00	294.00	336.00	378.00	420.00	462.00	14.00
	14	21	28	35	42	49	56	63	70	77	84	
	7	14	21	28	35	42	49	56	63	70	77	
	36.00	72.00	108.00	144.00	180.00	216.00	252.00	288.00	324.00	360.00	396.00	12.00
	12	18	24	30	36	42	48	54	60	66	72	
	6	12	18	24	30	36	42	48	54	60	66	
	30.00	60.00	90.00	120.00	150.00	180.00	210.00	240.00	270.00	300.00	330.00	10.00
	10	15	20	25	30	35	40	45	50	55	60	
	5	10	15	20	25	30	35	40	45	50	55	
	24.00	48.00	72.00	96.00	120.00	144.00	168.00	192.00	216.00	240.00	264.00	8.00
	8	12	16	20	24	28	32	36	40	44	48	
	4	8	12	16	20	24	28	32	36	40	44	
	18.00	36.00	54.00	72.00	90.00	108.00	126.00	144.00	162.00	180.00	198.00	6.00
	6	9	12	15	18	21	24	27	30	33	36	
	3	6	9	12	15	18	21	24	27	30	33	
	12.00	24.00	36.00	48.00	60.00	72.00	84.00	96.00	108.00	120.00	132.00	4.00
	4	6	8	10	12	14	16	18	20	22	24	
	2	4	6	8	10	12	14	16	18	20	22	
	6.00	12.00	18.00	24.00	30.00	36.00	42.00	48.00	54.00	60.00	66.00	2.00
	2	3	4	5	6	7	8	9	10	11	12	M.
	1	2	3	4	5	6	7	8	9	10	11	
LENGTH OF BASE	3.0	6.0	9.0	12.0	15.0	18.0	21.0	24.0	27.0	30.0	33.0	HT.

Mobile Tower

Mobile Tower with Vertical Frame

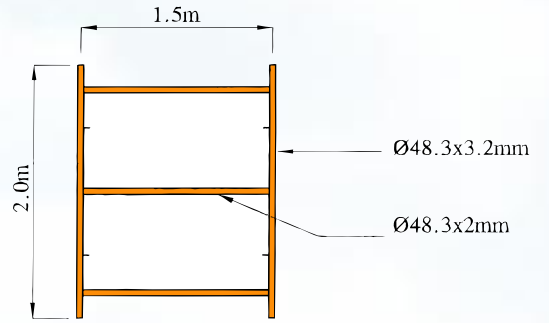
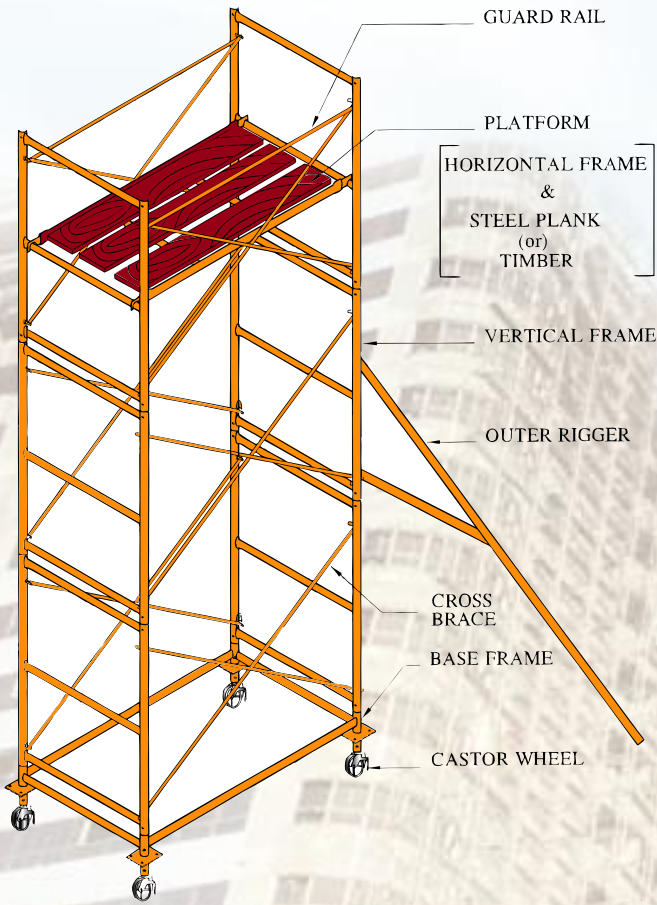

VERTICAL FRAME

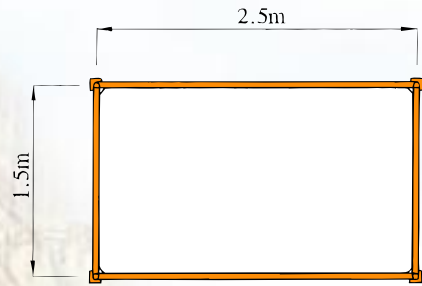

BASE FRAME

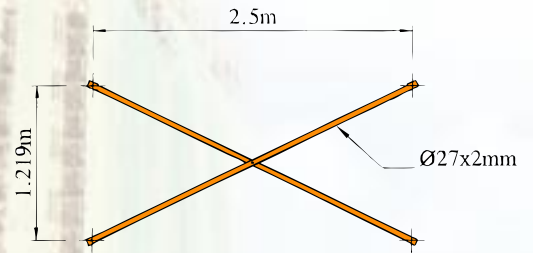

CROSS BRACE

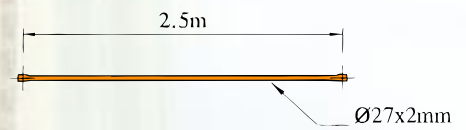

GUARD RAIL



CONNECTING PIN

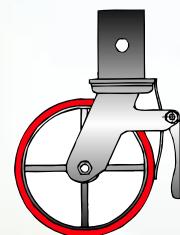

CASTOR WHEEL

Tower No.	1	2	3	4	5	6
Overall Height (m)	2.4	4.4	6.4	8.4	10.4	12.4
Platform Height (m)	1.4	3.4	5.4	7.4	9.4	11.4
Castor Wheel	4	4	4	4	4	4
Base Frame	1	1	1	1	1	1
Vertical Frame	2	4	6	8	10	12
Cross Brace	2	4	6	8	10	12
Horizontal Brace	2	2	2	2	2	2
Connecting Pin	4	8	12	16	20	24
Platform	1	1	1	1	1	1
Outer Rigger	-	-	4	4	4	4

Mobile Tower

Mobile Tower with K-Lock System

- Durable and easy to handle
- Minimal space required for storage
- Available with varying height from 3m to 12m
- Available with different base dimension (1.2 x 2.5m, 2.5 x 2.5m etc.)

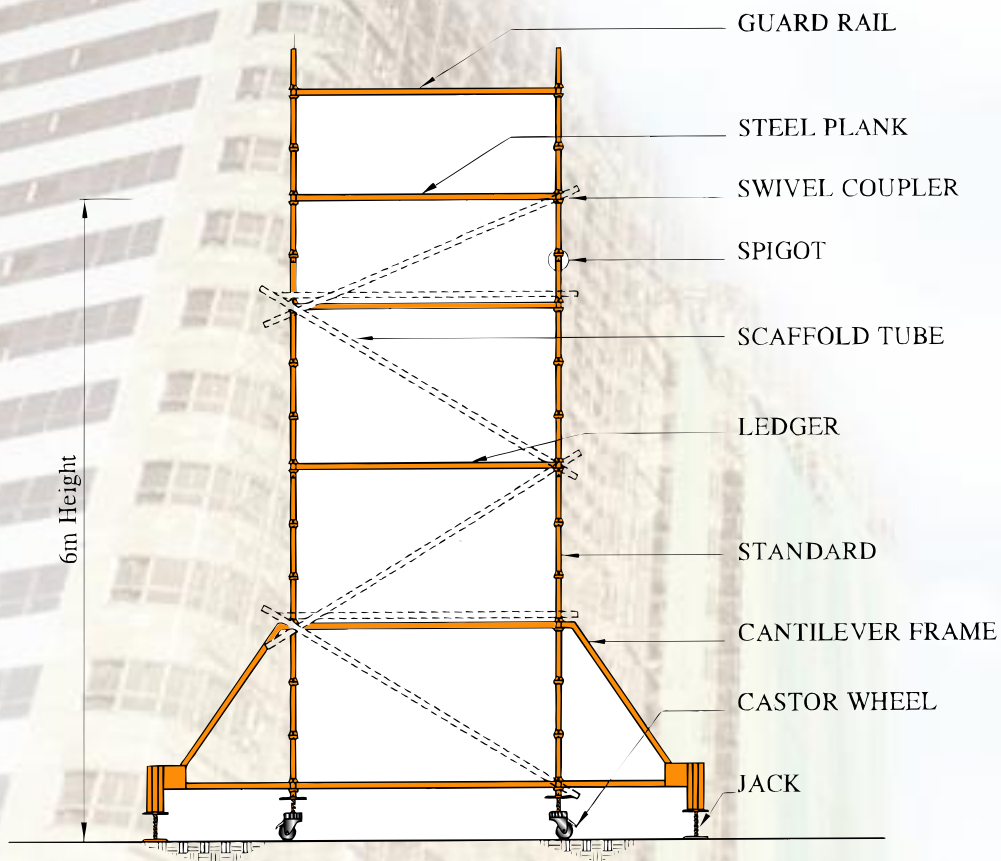

ELEVATION

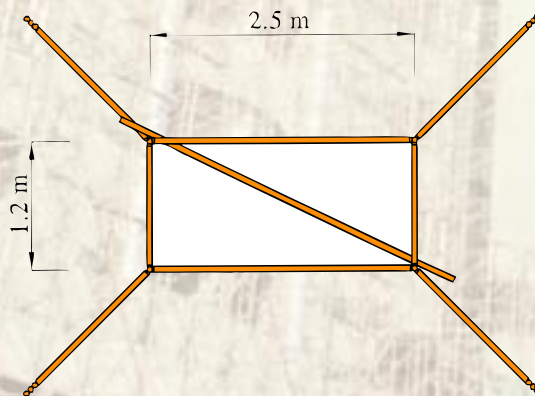

PLAN



K H K SCAFFOLDING & FORMWORK L.L.C.

Head Office:

New Industrial Area
P.O.Box: 2701, Ajman-U.A.E
Tel: +971-6-7439013, Fax: +971-6-7439017
E-mail: khkscaf@emirates.net.ae, Website: www.khk-scaffolding.com

Branches :

A-Val Metal Resources, Inc.

5925, Airport Road, Suite 200, Airway Centre,
Mississauga L4V 1W1, Ontario, Canada
Tel.: 001 905 405 6245, Fax: 001 905 672 8630
email : khk@avalmetal.com or hasiha@khk-scaffolding.com

Brisko Scaffolding Limited

120 South lane New Malden
Surrey KT3 SEL England
Tel.: 0044 - 20 - 83364595
Fax: 0044 - 20 - 83364596

Prime Metal CORPORATION - USA

653 Route 52, Walden NY 12586
United States of America
Tel.: 001 - 845 - 778 4545
Fax: 001 - 845 - 778 4218

Winston Scaffolding Pty Ltd.

44-46 Gould Street
South Strathfield, N.S.W. 2136
Tel.: 00 - 02 - 97588700
Fax: 00 - 02 - 97587263

